

Hexagon Nut – ISO 4032

Metric Series – Dimensions

Notes:-

1. The Nut will be according to ISO 4032 (IS 1364).
2. Threads will conform to Class 6H of ISO 724, ISO 965-1.
3. Material High grade carbon/alloy steel & stainless steel.
4. Heat Treatment: Property Class 8 or 10 .
5. Coating & Marking will be done as per requirement.
6. All dimensions are in millimetres.

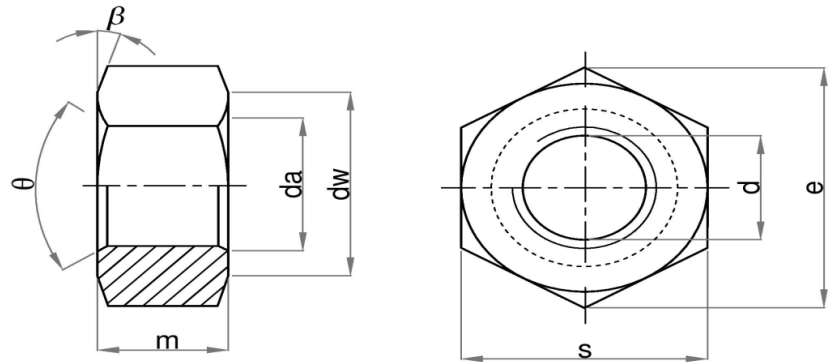

$$\beta = 15^\circ \text{ to } 30^\circ$$

$$\theta = 90^\circ \text{ to } 120^\circ$$

S. No.	Size	Pitch (p)	Width across corner (e)		Width across Flat (s)		Thickness (m)		da		dw		Minor diameter (Bore) (d)	
			Min.	Max.	Min.	Max.	Min.	Max.	Min.	Max.	Min.	Max.	Min.	Max.
1	M-16	2.0	26.75	23.67	24.00	14.10	14.80	16.00	17.30	22.50	12.10	12.20		
2	M-18	2.5	29.56	26.16	27.00	15.10	15.80	18.00	19.50	24.90	15.60	15.70		
3	M-20	2.5	32.95	29.16	30.00	15.45	16.65	20.00	21.60	27.70	17.60	17.70		
4	M-22	2.5	37.29	33.00	34.00	18.35	19.65	22.00	23.70	31.40	19.60	19.70		
5	M-24	3.0	39.55	35.00	36.00	18.35	19.65	24.00	25.90	33.30	20.70	20.80		
6	M-27	3.0	45.20	40.00	41.00	21.35	22.65	27.00	29.10	38.00	23.80	23.90		
7	M30	3.5	50.85	45.00	46.00	24.00	25.00	30.00	32.40	42.80	26.50	26.60		
8	M-33	3.5	55.37	49.00	50.00	25.35	26.65	33.00	35.60	46.60	29.20	29.30		
9	M-36	4.0	60.79	53.80	55.00	29.00	30.00	36.00	38.90	51.10	32.30	32.40		
10	M-39	4.0	66.44	58.80	60.00	30.20	31.80	39.00	42.10	55.90	35.10	35.20		
11	M-42	4.5	71.30	63.10	65.00	32.40	34.00	42.00	45.40	60.00	37.70	37.80		
12	M-45	4.5	76.95	68.10	70.00	34.40	36.00	45.00	48.60	64.70	40.90	41.00		
13	M-48	5.0	82.60	73.10	75.00	35.70	37.00	48.00	51.80	69.50	43.10	43.20		
14	M-52	5.0	88.25	78.10	80.00	40.50	42.00	52.00	56.20	74.20	47.50	47.60		
15	M-56	5.5	93.56	82.50	85.00	43.40	45.00	56.00	60.50	78.70	50.80	50.90		
16	M-60	5.5	99.21	87.80	90.00	47.00	48.00	60.00	64.80	83.40	54.90	55.00		
17	M-64	6.0	104.86	92.80	95.00	52.10	54.00	64.00	69.10	88.20	57.80	57.90		