

Note: This Drawing is the property of Kapil Enterprises-Kundli, and must not be copied or reproduced without permission or Written authorisation by Kapil Enterprises-Kundli

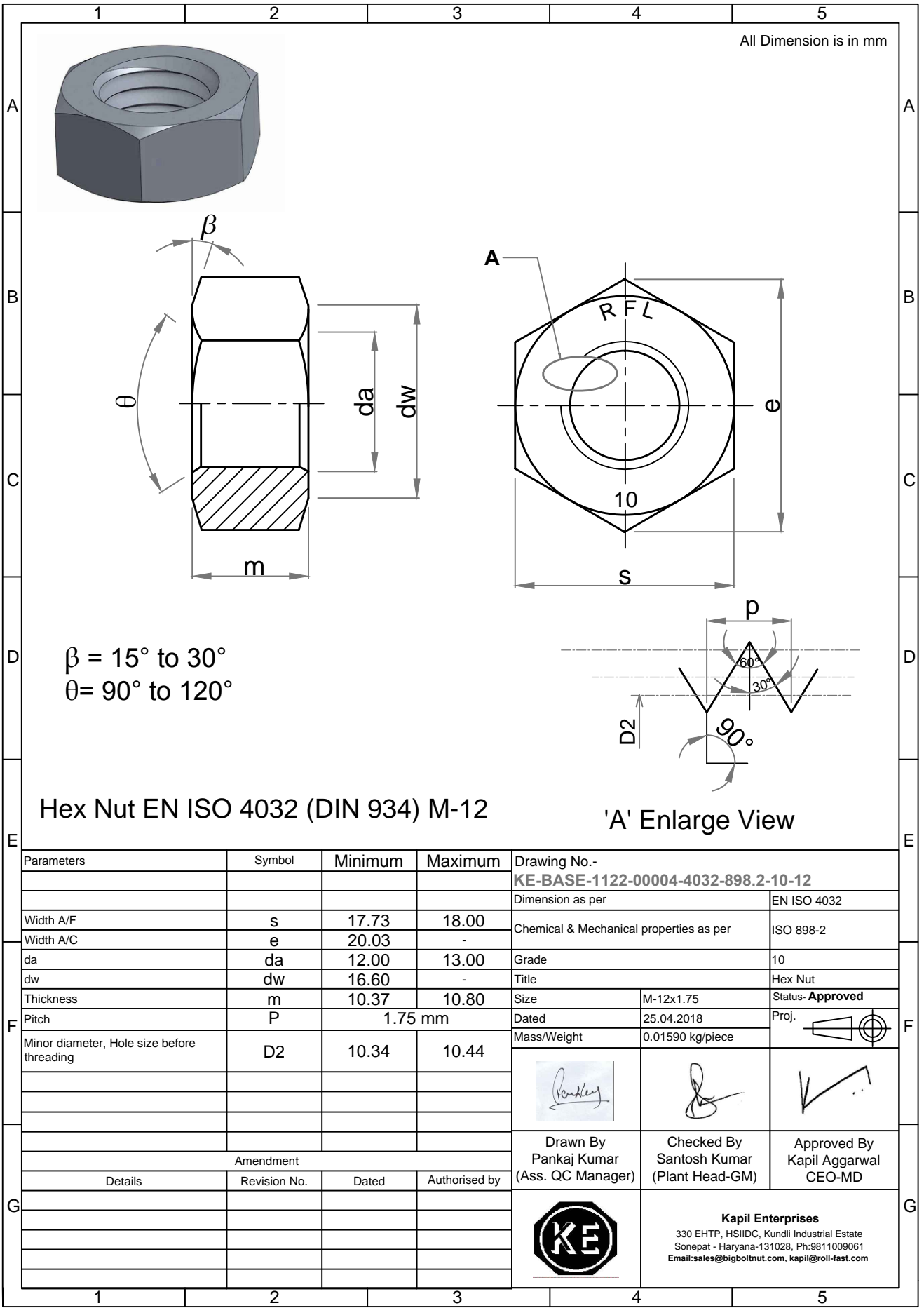

| Parameters | Symbol | Minimum | Maximum |
|--|--------------|---------|---------------|
| Width A/F | s | 17.73 | 18.00 |
| Width A/C | e | 20.03 | - |
| da | da | 12.00 | 13.00 |
| dw | dw | 16.60 | - |
| Thickness | m | 10.37 | 10.80 |
| Pitch | P | 1.75 mm | |
| Minor diameter, Hole size before threading | D2 | 10.34 | 10.44 |
| Amendment | | | |
| Details | Revision No. | Dated | Authorised by |
| | | | |
| | | | |
| | | | |

| | |
|--|--|
| Drawing No.- KE-BASE-1122-00004-4032-898.2-10-12 | |
| Dimension as per | EN ISO 4032 |
| Chemical & Mechanical properties as per | ISO 898-2 |
| Grade | 10 |
| Title | Hex Nut |
| Size | M-12x1.75 |
| Dated | 25.04.2018 |
| Mass/Weight | 0.01590 kg/piece |
| Proj. | |
| Drawn By Pankaj Kumar (Ass. QC Manager) | Checked By Santosh Kumar (Plant Head-GM) |
| Approved By Kapil Aggarwal CEO-MD | |
| | |
| Kapil Enterprises 330 EHTP, HSIIDC, Kundli Industrial Estate Sonapat - Haryana-131028, Ph:9811009061 Email:sales@bigboltnut.com, kapil@roll-fast.com | |