

Note: This Drawing is the property of Kapil Enterprises-Kundli, and must not be copied or reproduced without permission or Written authorisation by Kapil Enterprises-Kundli

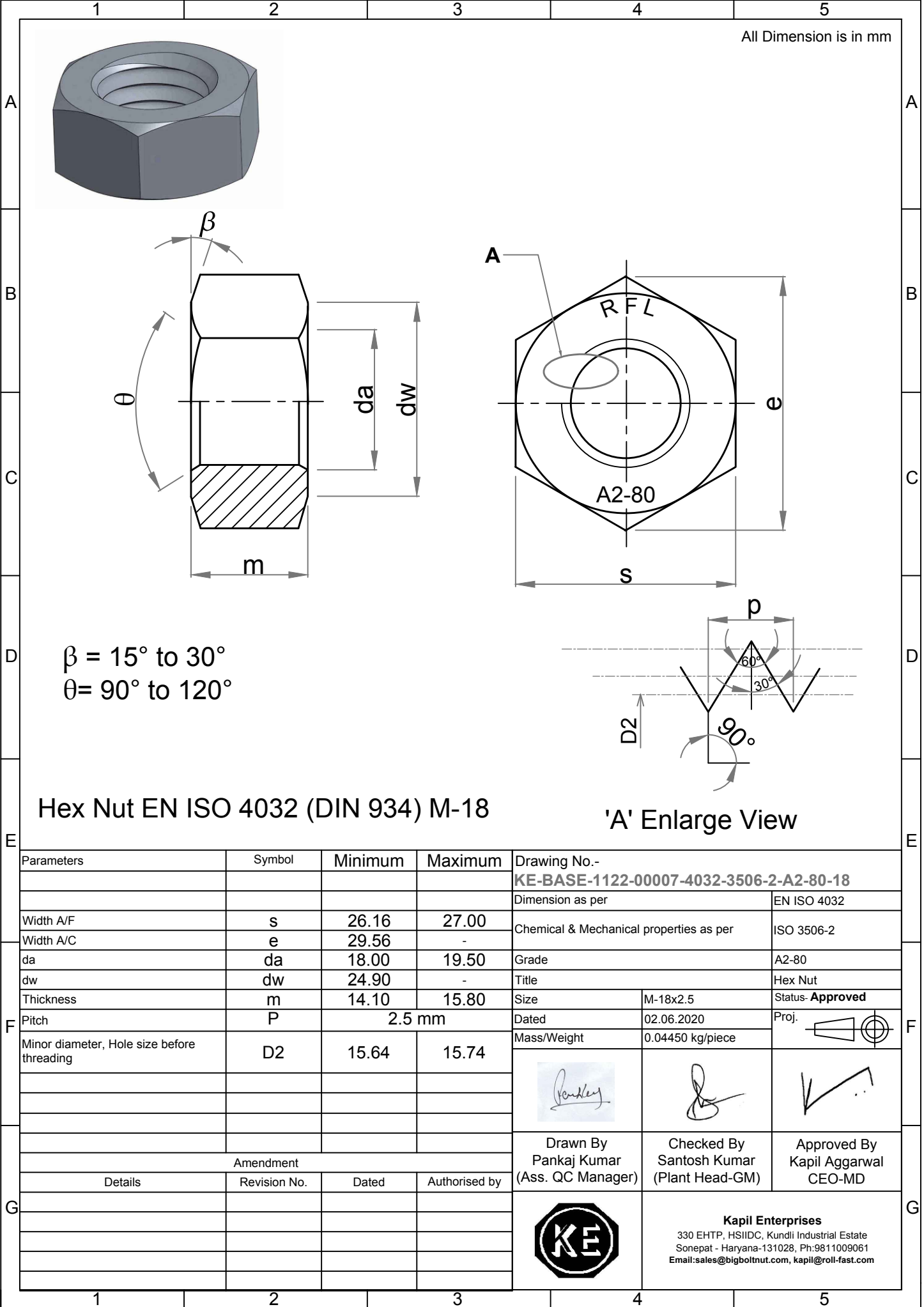



All Dimension is in mm

$\beta = 15^\circ \text{ to } 30^\circ$   
 $\theta = 90^\circ \text{ to } 120^\circ$

**Hex Nut EN ISO 4032 (DIN 934) M-18**

**'A' Enlarge View**

Parameters	Symbol	Minimum	Maximum	Drawing No.- <b>KE-BASE-1122-00007-4032-3506-2-A2-80-18</b>		
				Dimension as per	EN ISO 4032	
Width A/F	s	26.16	27.00	Chemical & Mechanical properties as per	ISO 3506-2	
Width A/C	e	29.56	-	Grade	A2-80	
da	da	18.00	19.50	Title	Hex Nut	
dw	dw	24.90	-	Size	M-18x2.5	
Thickness	m	14.10	15.80	Status-	<b>Approved</b>	
Pitch	P	2.5 mm		Dated	02.06.2020	
Minor diameter, Hole size before threading	D2	15.64	15.74	Mass/Weight	0.04450 kg/piece	
Amendment				 Drawn By <b>Pankaj Kumar</b> (Ass. QC Manager)	 Checked By <b>Santosh Kumar</b> (Plant Head-GM)	 Approved By <b>Kapil Aggarwal</b> CEO-MD
Details	Revision No.	Dated	Authorised by			
				<b>Kapil Enterprises</b> 330 EHTP, HSIIDC, Kundli Industrial Estate Sonapat - Haryana-131028, Ph:9811009061 Email:sales@bigboltnut.com, kapil@roll-fast.com		

