

Note: This Drawing is the property of Kapil Enterprises-Kundli, and must not be copied or reproduced without permission or Written authorisation by Kapil Enterprises-Kundli

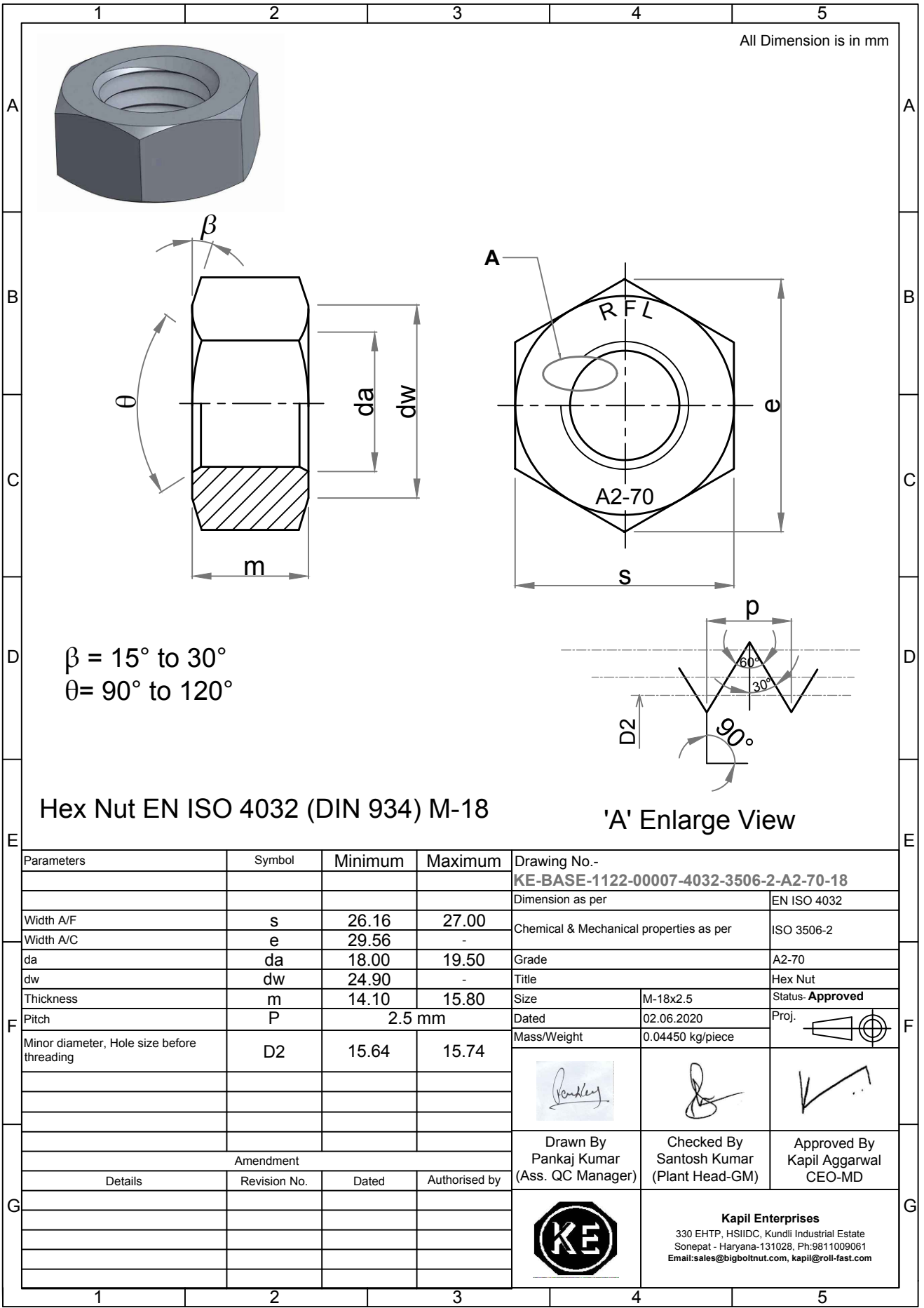

All Dimension is in mm

$\beta = 15^\circ \text{ to } 30^\circ$
 $\theta = 90^\circ \text{ to } 120^\circ$

Hex Nut EN ISO 4032 (DIN 934) M-18

'A' Enlarge View

Parameters	Symbol	Minimum	Maximum	Drawing No.- KE-BASE-1122-00007-4032-3506-2-A2-70-18	
				Dimension as per	EN ISO 4032
Width A/F	s	26.16	27.00	Chemical & Mechanical properties as per	ISO 3506-2
Width A/C	e	29.56	-	Grade	A2-70
da	da	18.00	19.50	Title	Hex Nut
dw	dw	24.90	-	Size	M-18x2.5
Thickness	m	14.10	15.80	Status	Approved
Pitch	P	2.5 mm		Dated	02.06.2020
Minor diameter, Hole size before threading	D2	15.64	15.74	Mass/Weight	0.04450 kg/piece
				Proj.	
Amendment				Drawn By	Checked By
Details	Revision No.	Dated	Authorised by	Pankaj Kumar (Ass. QC Manager)	Santosh Kumar (Plant Head-GM)
				Approved By	Kapil Aggarwal CEO-MD
				Kapil Enterprises 330 EHTP, HSIIDC, Kundli Industrial Estate Sonapat - Haryana-131028, Ph:9811009061 Email:sales@bigboltnut.com, kapil@roll-fast.com	