

Note: This Drawing is the property of Kapil Enterprises-Kundli, and must not be copied or reproduced without permission or Written authorisation by Kapil Enterprises-Kundli

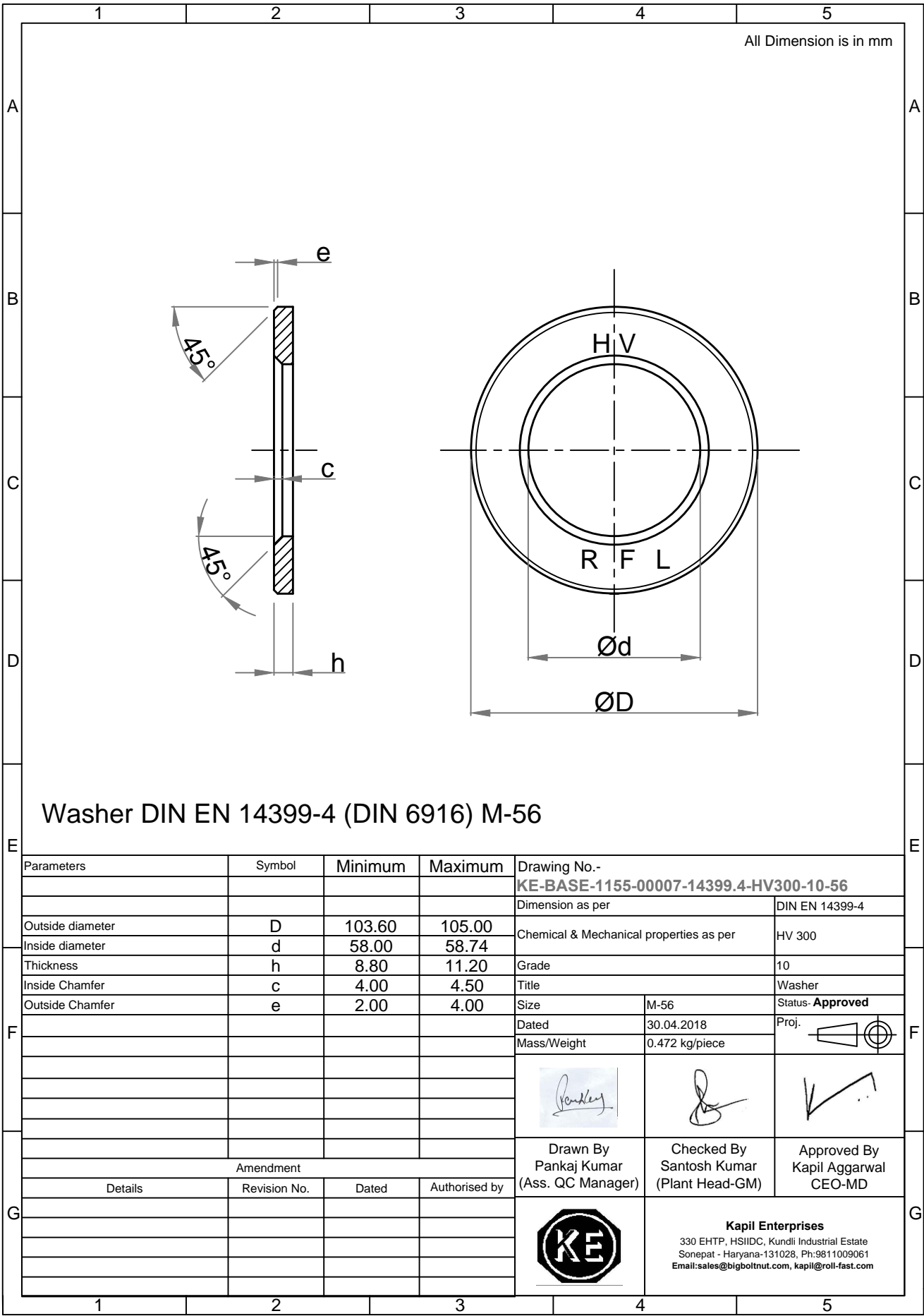

All Dimension is in mm

Washer DIN EN 14399-4 (DIN 6916) M-56

Parameters	Symbol	Minimum	Maximum	Drawing No.- KE-BASE-1155-00007-14399.4-HV300-10-56	
				Dimension as per	DIN EN 14399-4
Outside diameter	D	103.60	105.00	Chemical & Mechanical properties as per	HV 300
Inside diameter	d	58.00	58.74	Grade	10
Thickness	h	8.80	11.20	Title	Washer
Inside Chamfer	c	4.00	4.50	Size	M-56
Outside Chamfer	e	2.00	4.00	Dated	30.04.2018
				Mass/Weight	0.472 kg/piece
					Proj.
Amendment				Drawn By Pankaj Kumar (Ass. QC Manager)	Checked By Santosh Kumar (Plant Head-GM)
Details	Revision No.	Dated	Authorised by	Approved By Kapil Aggarwal CEO-MD	
				<p>Kapil Enterprises 330 EHTP, HSIIDC, Kundli Industrial Estate Sonepat - Haryana-131028, Ph:9811009061 Email:sales@bigboltnut.com, kapil@roll-fast.com</p>	