

Note: This Drawing is the property of Kapil Enterprises-Kundli, and must not be copied or reproduced without permission or Written authorisation by Kapil Enterprises-Kundli

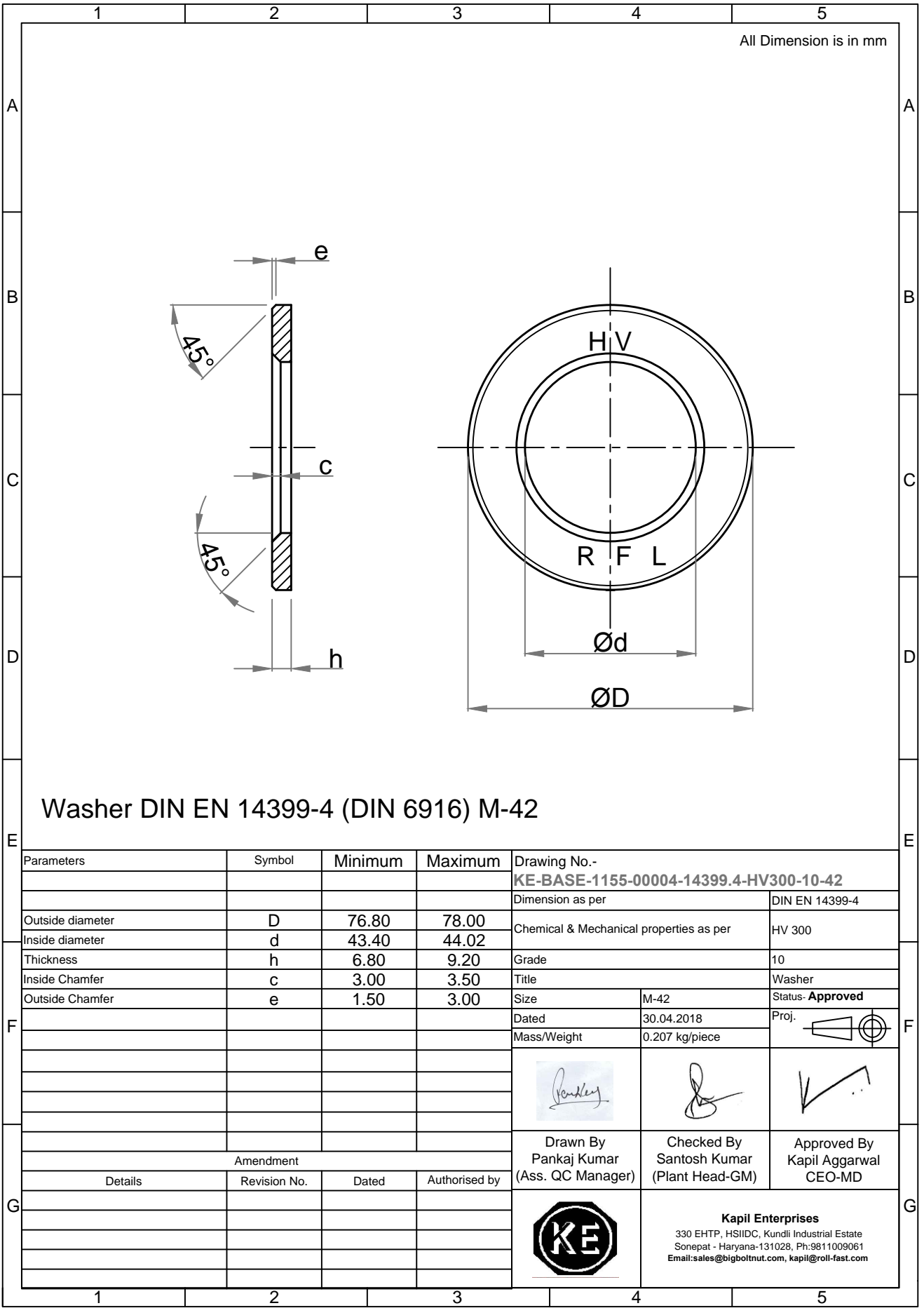

All Dimension is in mm

Washer DIN EN 14399-4 (DIN 6916) M-42

Parameters	Symbol	Minimum	Maximum
Outside diameter	D	76.80	78.00
Inside diameter	d	43.40	44.02
Thickness	h	6.80	9.20
Inside Chamfer	c	3.00	3.50
Outside Chamfer	e	1.50	3.00
Amendment			
Details	Revision No.	Dated	Authorised by

Drawing No.- KE-BASE-1155-00004-14399.4-HV300-10-42	
Dimension as per	DIN EN 14399-4
Chemical & Mechanical properties as per	HV 300
Grade	10
Title	Washer
Size	M-42
Dated	30.04.2018
Mass/Weight	0.207 kg/piece
Proj.	
Drawn By Pankaj Kumar (Ass. QC Manager)	Checked By Santosh Kumar (Plant Head-GM)
Approved By Kapil Aggarwal CEO-MD	
Kapil Enterprises 330 EHTP, HSIIDC, Kundli Industrial Estate Sonapat - Haryana-131028, Ph:9811009061 Email:sales@bigboltnut.com, kapil@roll-fast.com	