

Note: This Drawing is the property of Kapil Enterprises-Kundli, and must not be copied or reproduced without permission or Written authorisation by Kapil Enterprises-Kundli

All Dimension is in mm

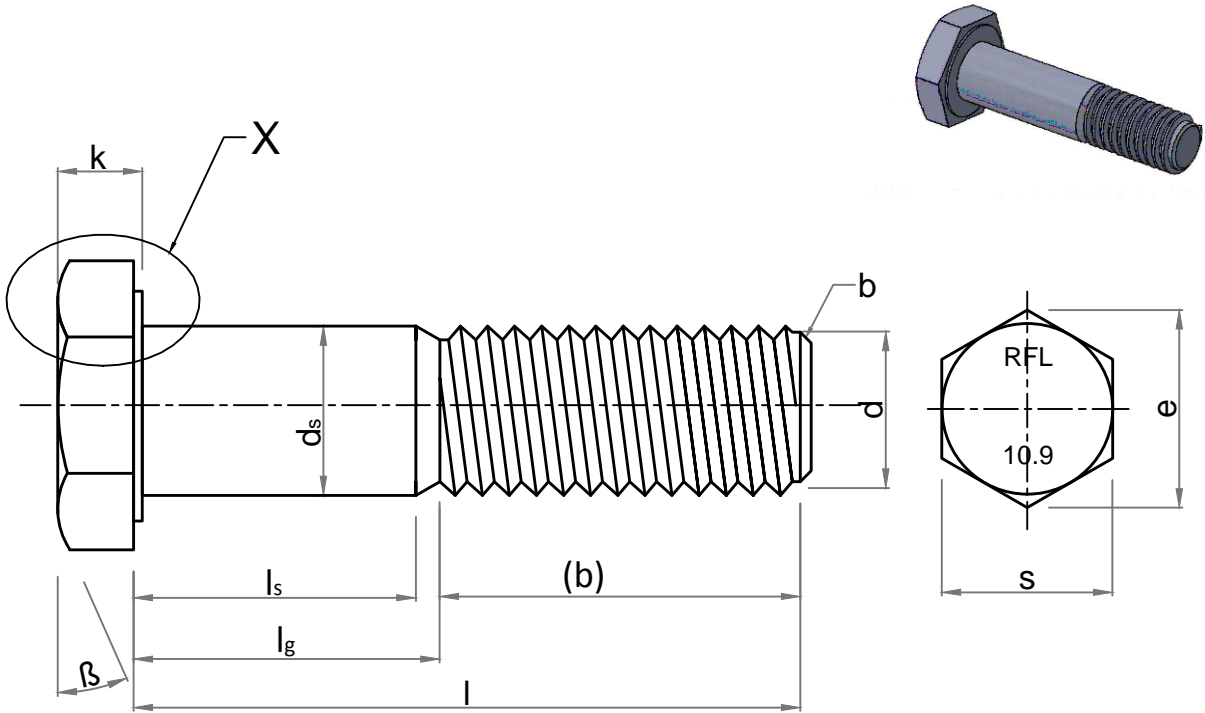

Note:

- a. $\beta = 15^\circ$ to 30°
- b. Point shall be chamfered on for threads $< M4$ may be as-rolled (sheared end) in accordance with ISO 4753.
- c. Incomplete thread $\mu < 2P$.
- d. Reference datum for d_w .
- e. Maximum underhead fillet.



Hex Bolt DIN EN 14399-4 M-36x180

'X' Enlarge View

Parameters	Symbol	Minimum	Maximum
Raw material grade	G		
Raw material diameter	D	36.50	37.50
Head thickness	k	21.95	24.05
Width A/F	s	58.80	60.00
Width A/C	e	66.44	-
Shank diameter	ds	35.00	37.00
Major diameter	D	35.46	35.94
Pitch diameter	D1	33.12	33.34
Minor diameter	D2	-	31.61
Threading length	(b)	52.00	59.00
Shank length	ls	116.00	-
Total Shank length	lg	-	128.00
Total length of bolt	l	178.00	182.00
da	da	-	41.00
dw	dw	55.90	-
Radius of fillet	r	2.00	-
c	c	0.40	0.80
Chamfer	b	0.00	8.00
Amendment			
Details	Revision No.	Dated	Authorised by

Drawing No.- KE-BASE-1133-00026-14399.4-898.1-10.9-36x180		
Dimension as per	DIN EN 14399-4	
Mechanical properties as per	ISO 898-1	
Grade	10.9	
Size	36x180	
Pitch	4.00	
Title	Hex Bolt	Status- Approved
Dated	17.04.2018	Proj.
Mass/Weight	1.904 kg/piece	
 Drawn By Pankaj Kumar (Ass. QC Manager)	 Checked By Santosh Kumar (Plant Head-GM)	 Approved By Kapil Aggarwal CEO-MD
Kapil Enterprises 330 EHTP, HSIIDC, Kundli Industrial Estate Sonepat - Haryana-131028, Ph:9811009061 Email:sales@bigboltnut.com, kapil@roll-fast.com		