

Note: This Drawing is the property of Kapil Enterprises-Kundli, and must not be copied or reproduced without permission or Written authorisation by Kapil Enterprises-Kundli

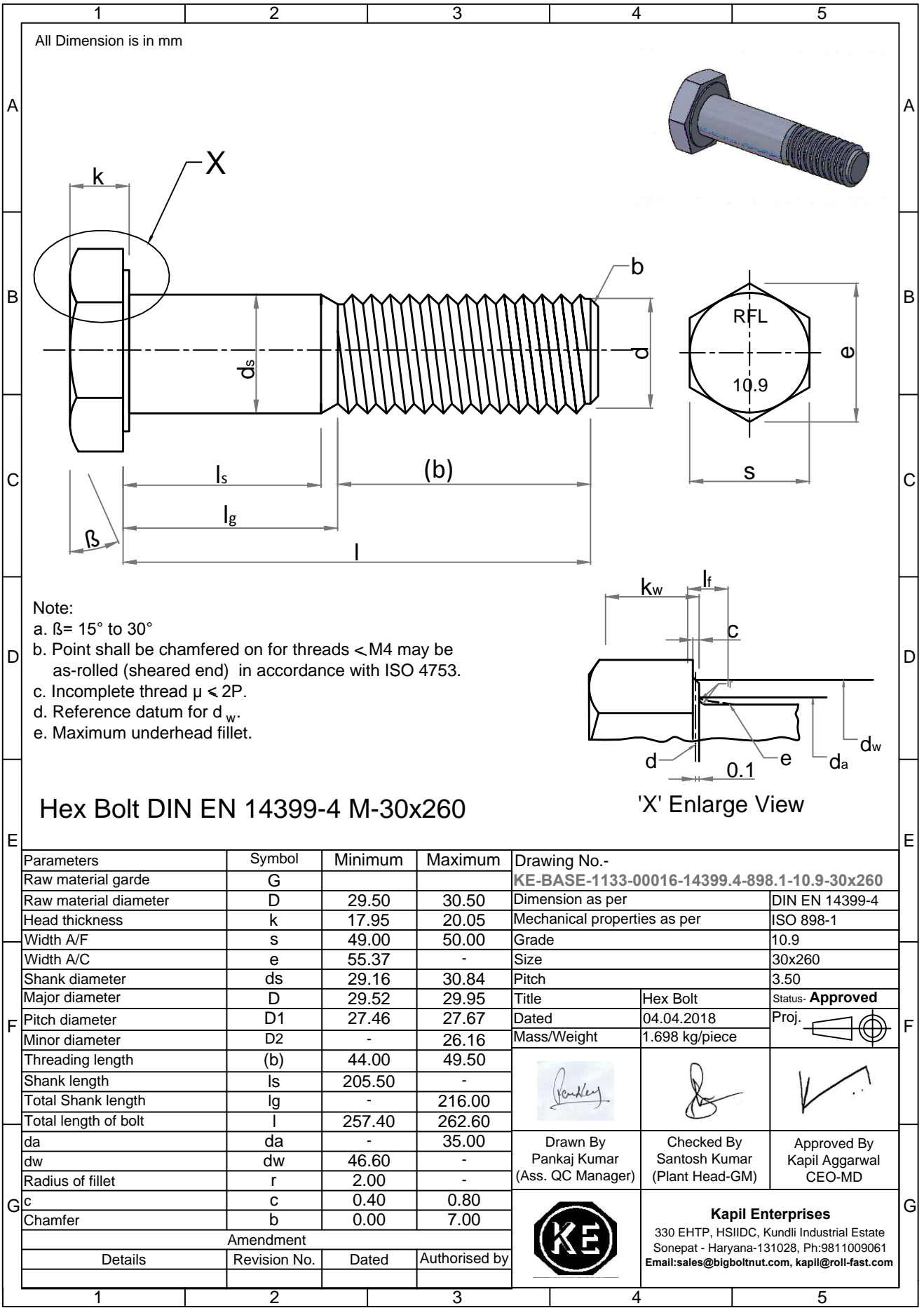

All Dimension is in mm

- Note:
- a. $\beta = 15^\circ$ to 30°
 - b. Point shall be chamfered on for threads $< M4$ may be as-rolled (sheared end) in accordance with ISO 4753.
 - c. Incomplete thread $\mu < 2P$.
 - d. Reference datum for d_w .
 - e. Maximum underhead fillet.

Hex Bolt DIN EN 14399-4 M-30x260

'X' Enlarge View

Parameters	Symbol	Minimum	Maximum
Raw material grade	G		
Raw material diameter	D	29.50	30.50
Head thickness	k	17.95	20.05
Width A/F	s	49.00	50.00
Width A/C	e	55.37	-
Shank diameter	d_s	29.16	30.84
Major diameter	D	29.52	29.95
Pitch diameter	D1	27.46	27.67
Minor diameter	D2	-	26.16
Threading length	(b)	44.00	49.50
Shank length	l_s	205.50	-
Total Shank length	l_g	-	216.00
Total length of bolt	l	257.40	262.60
d_a	d_a	-	35.00
d_w	d_w	46.60	-
Radius of fillet	r	2.00	-
c	c	0.40	0.80
Chamfer	b	0.00	7.00
Amendment			
Details	Revision No.	Dated	Authorised by

Drawing No.- **KE-BASE-1133-00016-14399.4-898.1-10.9-30x260**

Dimension as per	DIN EN 14399-4	
Mechanical properties as per	ISO 898-1	
Grade	10.9	
Size	30x260	
Pitch	3.50	
Title	Hex Bolt	Status- Approved
Dated	04.04.2018	Proj.
Mass/Weight	1.698 kg/piece	
 Drawn By Pankaj Kumar (Ass. QC Manager)	 Checked By Santosh Kumar (Plant Head-GM)	 Approved By Kapil Aggarwal CEO-MD
Kapil Enterprises 330 EHTP, HSIIDC, Kundli Industrial Estate Sonepat - Haryana-131028, Ph:9811009061 Email:sales@bigboltnut.com, kapil@roll-fast.com		