

Note: This Drawing is the property of Kapil Enterprises-Kundli, and must not be copied or reproduced without permission or Written authorisation by Kapil Enterprises-Kundli

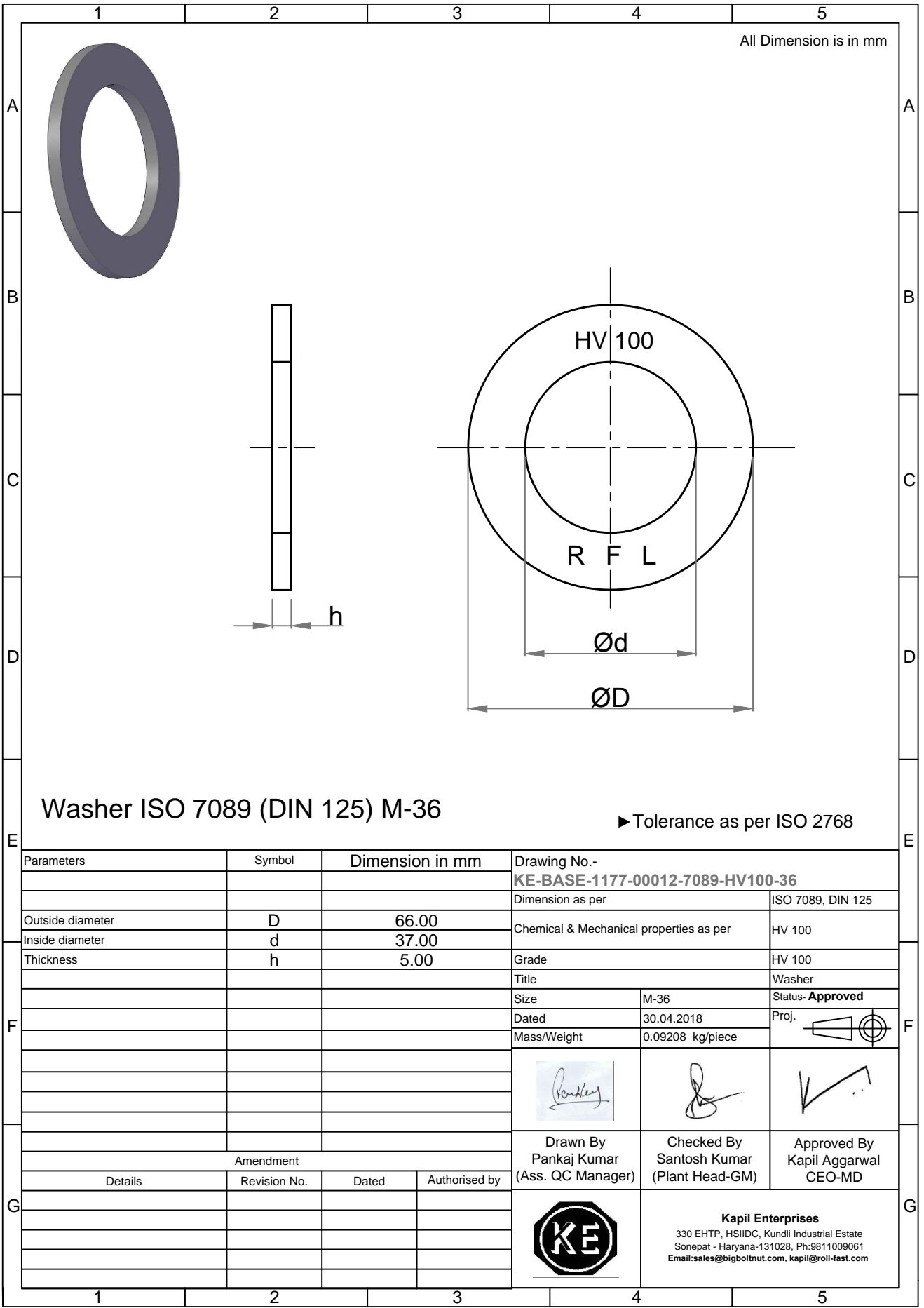

All Dimension is in mm

Washer ISO 7089 (DIN 125) M-36

► Tolerance as per ISO 2768

Parameters		Symbol	Dimension in mm	Drawing No.- KE-BASE-1177-00012-7089-HV100-36	
				Dimension as per ISO 7089, DIN 125	
Outside diameter		D	66.00	Chemical & Mechanical properties as per HV 100	
Inside diameter		d	37.00	Grade HV 100	
Thickness		h	5.00	Title Washer	
				Size M-36 Status- Approved	
				Dated 30.04.2018 Proj.	
				Mass/Weight 0.09208 kg/piece	
				Drawn By Pankaj Kumar (Ass. QC Manager) Checked By Santosh Kumar (Plant Head-GM) Approved By Kapil Aggarwal CEO-MD	
Amendment				<p>Kapil Enterprises 330 EHTP, HSIIDC, Kundli Industrial Estate Sonepat - Haryana-131028, Ph:9811009061 Email:sales@bigboltnut.com, kapil@roll-fast.com</p>	
Details	Revision No.	Dated	Authorised by		